

APPROVED

FOR REFERENCE ONLY

SOCKET SET SCREW, M4x0.7 x 4mm, CUP POINT, 18-8 STAINLESS ST'L 2X

REVISIONS				
ZONE	REV.	DESCRIPTION	DATE	APPROVED
	A	INITIAL RELEASE	7/24/2019	JP

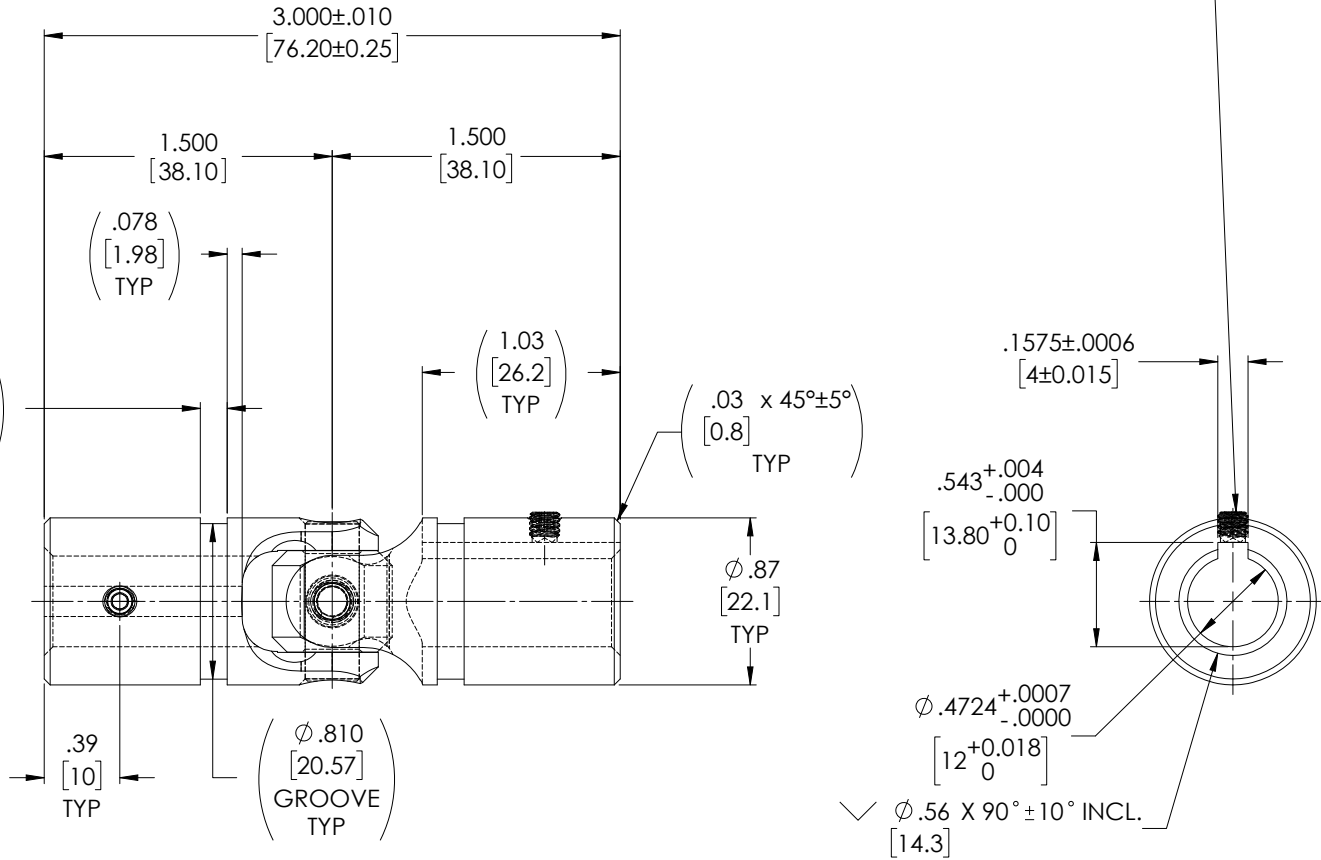
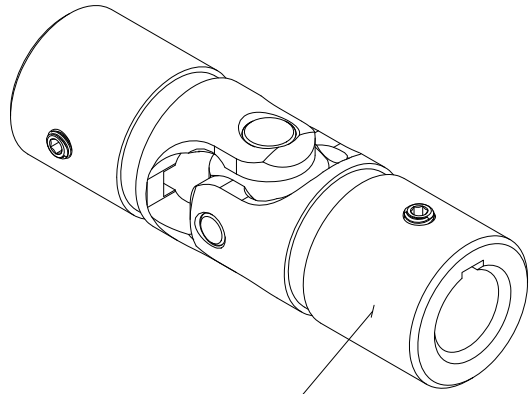

TYPICAL BOTH ENDS

NOTE(s), UNLESS OTHERWISE SPECIFIED.

1 MARK ASSEMBLY w/ "BELDEN" LOGO, PART NUMBER, REVISION LEVEL (IF ANY), DATE OF MANUFACTURE & BELDEN JOB No.

(2) LUBRICATE U-JOINT w/ LUBRIPLATE # 1200-2, NLGI GRADE 2, AW/EP, LITHIUM GREASE OR EQUIVALENT.

(3) REFERENCE, MATERIAL: YOKES... TYPE 303 STAINLESS STEEL,
BLOCK & PINS... TYPE 416 STAINLESS STEEL,
RETAINING RING... TYPE 302 STAINLESS STEEL.

(4) REF., MAXIMUM OPERATING ANGLE: 45°

DO NOT SCALE DRAWING

UNLESS OTHERWISE SPECIFIED CHAMFER ALL HOLES BREAK ALL SHARP CORNERS DE-BURR ALL FEATURES TURNED SURFACES: $\sqrt{63}$ MILLED SURFACES: $\sqrt{125}$ PROPRIETARY AND CONFIDENTIAL THE INFORMATION CONTAINED IN THIS DRAWING IS THE SOLE PROPERTY OF BELDEN UNIVERSAL. ANY REPRODUCTION IN PART OR AS A WHOLE WITHOUT THE WRITTEN PERMISSION OF BELDEN UNIVERSAL IS PROHIBITED.	STANDARD TOLERANCES, UNLESS OTHERWISE SPECIFIED DIMENSIONS ARE IN INCHES [mm] ANGULAR MACHINED: ±1.0° FRACTIONAL: ±.015° TWO PLACE DECIMAL: ±.010° THREE PLACE DECIMAL: ±.005° FOUR PLACE DECIMAL: ±.0005° CONCENTRICITY: .0025" T.I.R.	MATERIAL: STAINLESS STEEL HEAT TREAT: SEE DETAIL DRAWINGS FINISH: NONE	INITIALS: JP DATE: 24JUL19 CHECKED: RNK 09/09/2019 ENG APPR: RNK 09/16/2019 MFG APPR: QC APPR:	Belden Incorporated www.beldenuniversal.com TITLE: ASSEMBLY, UNIVERSAL JOINT SIZE: A DWG. NO.: UJ-SS875x12K SCALE: 2:1 WT (Lbs): 0.333 SHEET 1 OF 2	REV: A
	ALL HOLES TO BE LOCATED ON CENTERLINE (C) WITHIN .005" T.I.R. INTERPRET GEOMETRIC TOLERANCES I.A.W. ASME Y14.5				
	COMMENTS:				
	SCALE: 2:1 WT (Lbs): 0.333 SHEET 1 OF 2				