

SCALE 3 : 1

INFORMATION IN THIS DRAWING PROVIDED FOR REFERENCE ONLY

REVISIONS				
ZONE	REV.	DESCRIPTION	DATE	APPROVED

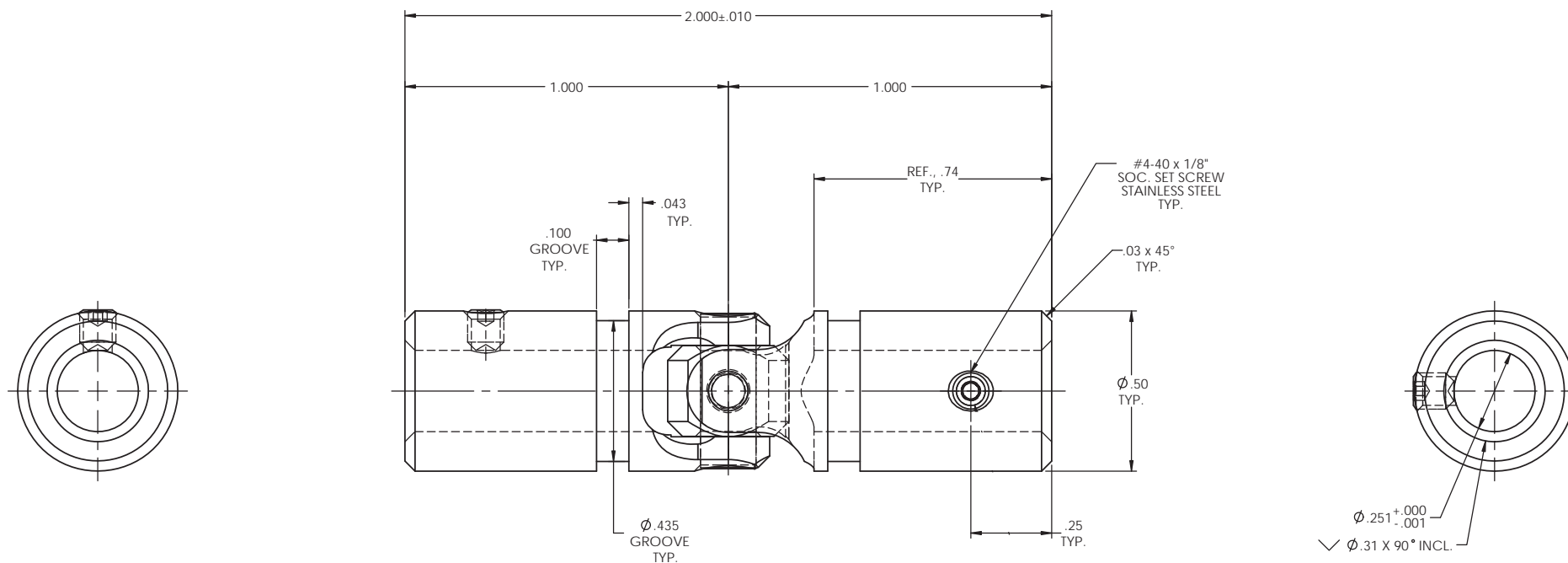

NOTE(s), UNLESS OTHERWISE SPECIFIED.

- (1) UNIVERSAL JOINT IS MARKED w/ "BELDEN" LOGO, PART NUMBER / DRAWING NUMBER, REVISION LEVEL (IF ANY), DATE OF MANUFACTURE (MO/YR), AND BELDEN JOB NUMBER.
- (2) UNIVERSAL JOINT IS LUBRICATED w/ LUBRIPLATE 1200-2, NLGI GRADE 2, AW/EP, LITHIUM GREASE OR EQUIVALENT.
- (3) UNIVERSAL JOINT IS CAPABLE OF OPERATING AT ANY ANGLE UP TO AND INCLUDING 45°.
- (4) UNIVERSAL JOINT HAS STANDARD GROOVES TO ACCEPT INSTALLATION OF PROTECTIVE COVER (BOOT). BOOT AVAILABLE SEPARATELY. REFER TO BELDEN CATALOG, WEBSITE, OR CONTACT BELDEN SALES.
- (5) REFER TO BELDEN CATALOG, WEBSITE, OR CONTACT BELDEN SALES FOR TORQUE CAPACITY.
- (6) THIS DRAWING REPRESENTS A STANDARD BELDEN ITEM. CUSTOM UNIVERSAL JOINTS ARE AVAILABLE UPON REQUEST. PLEASE CONTACT BELDEN SALES.

BELDEN PART NUMBER: UJ-SS500x250-1SS

DO NOT SCALE DRAWING

UNLESS OTHERWISE SPECIFIED CHAMFER ALL HOLES BREAK ALL SHARP CORNERS DE-BURR ALL FEATURES TURNED SURFACES: $\sqrt{63}$ MILLED SURFACES: $\sqrt{125}$ PROPRIETARY AND CONFIDENTIAL THE INFORMATION CONTAINED IN THIS DRAWING IS THE SOLE PROPERTY OF BELDEN INCORPORATED. ANY REPRODUCTION IN PART OR AS A WHOLE WITHOUT THE WRITTEN PERMISSION OF BELDEN INCORPORATED IS PROHIBITED.	STANDARD TOLERANCES, UNLESS OTHERWISE SPECIFIED DIMENSIONS ARE IN INCHES [mm]	MATERIAL: STAINLESS STEEL HEAT TREAT: SEE DETAIL DRAWINGS FINISH: NONE	NAME: JP DATE: 23MAR12 DRAWN: RNK CHECKED: RNK ENG APPR: RNK MFG APPR: RNK D/A:	Belden Incorporated www.beldenuniversal.com TITLE: ASSEMBLY, UNIVERSAL JOINT
	ANGULAR MACHINED: ±1.0° FRACTIONAL: ±.015" TWO PLACE DECIMAL: ±.010" THREE PLACE DECIMAL: ±.005" FOUR PLACE DECIMAL: ±.0005" CONCENTRICITY: .0005" T.I.R.	ALL HOLES TO BE LOCATED ON CENTERLINE (C) WITHIN .005" T.I.R. INTERPRET GEOMETRIC TOLERANCES I.A.W. ANSI Y14.5M-1992	COMMENTS:	SIZE: C DWG. NO.: UJ-SS500x250-1SS SCALE: 4:1 WT (Lbs): 0.076 SHEET 1 OF 2
	REVISIONS	MATERIAL: STAINLESS STEEL	NAME: JP DATE: 23MAR12	TITLE: ASSEMBLY, UNIVERSAL JOINT
	UNLESS OTHERWISE SPECIFIED CHAMFER ALL HOLES BREAK ALL SHARP CORNERS DE-BURR ALL FEATURES TURNED SURFACES: $\sqrt{63}$ MILLED SURFACES: $\sqrt{125}$ PROPRIETARY AND CONFIDENTIAL THE INFORMATION CONTAINED IN THIS DRAWING IS THE SOLE PROPERTY OF BELDEN INCORPORATED. ANY REPRODUCTION IN PART OR AS A WHOLE WITHOUT THE WRITTEN PERMISSION OF BELDEN INCORPORATED IS PROHIBITED.	STANDARD TOLERANCES, UNLESS OTHERWISE SPECIFIED DIMENSIONS ARE IN INCHES [mm] ANGULAR MACHINED: ±1.0° FRACTIONAL: ±.015" TWO PLACE DECIMAL: ±.010" THREE PLACE DECIMAL: ±.005" FOUR PLACE DECIMAL: ±.0005" CONCENTRICITY: .0005" T.I.R. ALL HOLES TO BE LOCATED ON CENTERLINE (C) WITHIN .005" T.I.R. INTERPRET GEOMETRIC TOLERANCES I.A.W. ANSI Y14.5M-1992	MATERIAL: STAINLESS STEEL HEAT TREAT: SEE DETAIL DRAWINGS FINISH: NONE	NAME: JP DATE: 23MAR12 DRAWN: RNK CHECKED: RNK ENG APPR: RNK MFG APPR: RNK D/A: COMMENTS: