

REVISIONS				
ZONE	REV.	DESCRIPTION	DATE	APPROVED

INFORMATION IN THIS DRAWING PROVIDED FOR REFERENCE ONLY

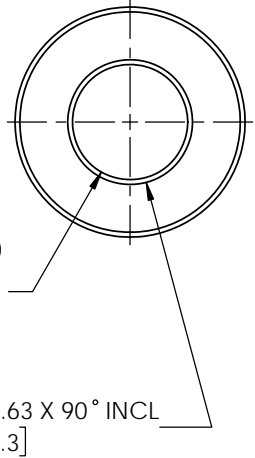
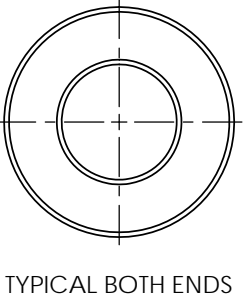
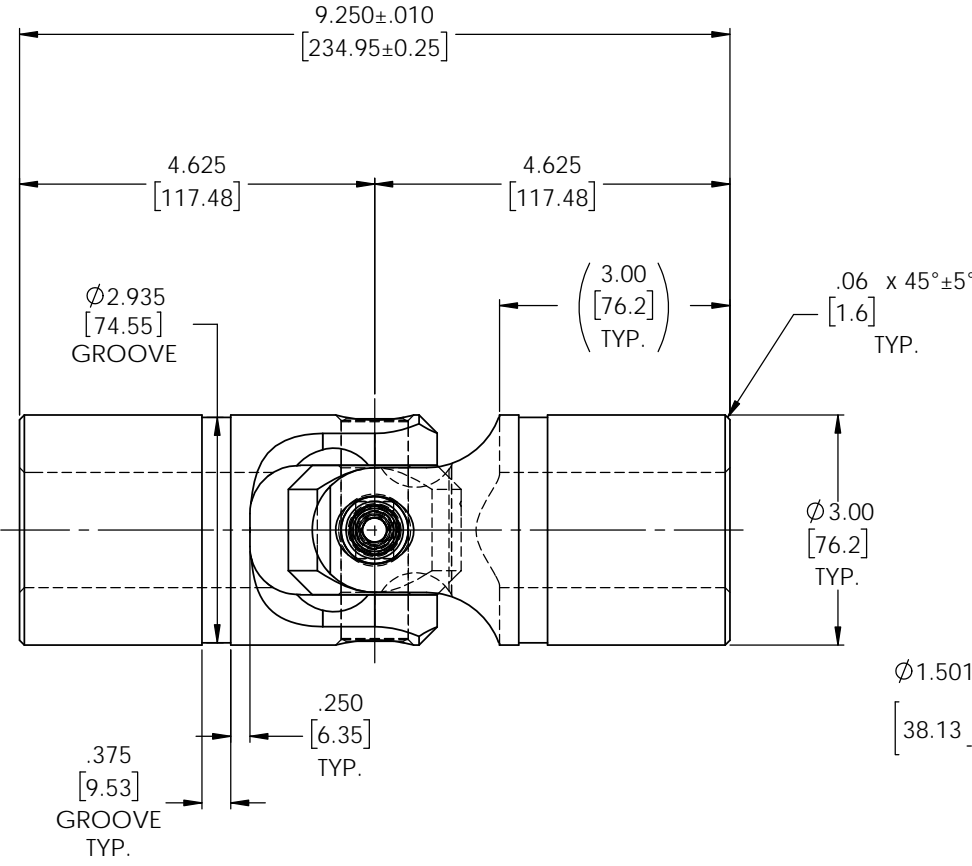
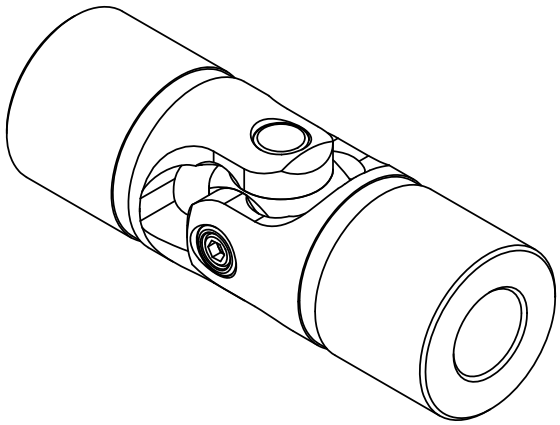

BELDEN PART NUMBER: UJ-SS3000x1500

NOTE(s), UNLESS OTHERWISE SPECIFIED.

- (1) UNIVERSAL JOINT IS MARKED w/ "BELDEN" LOGO, PART NUMBER / DRAWING NUMBER, REVISION LEVEL (IF ANY), DATE OF MANUFACTURE (MO/YR), AND BELDEN JOB NUMBER.
- (2) UNIVERSAL JOINT IS LUBRICATED w/ LUBRIPLATE 1200-2, NLGI GRADE 2, AW/EP, LITHIUM GREASE OR EQUIVALENT.
- (3) UNIVERSAL JOINT IS CAPABLE OF OPERATING AT ANY ANGLE UP TO AND INCLUDING 45°, 90° FOR THE DOUBLE UNIVERSAL JOINT.
- (4) UNIVERSAL JOINT HAS STANDARD GROOVES TO ACCEPT INSTALLATION OF PROTECTIVE COVERS (Boots).

DO NOT SCALE DRAWING

UNLESS OTHERWISE SPECIFIED CHAMFER ALL HOLES BREAK ALL SHARP CORNERS BREAK ALL FEATURES TURNED SURFACES: $\sqrt{63}$ MILLED SURFACES: $\sqrt{125}$ PROPRIETARY AND CONFIDENTIAL THE INFORMATION CONTAINED IN THIS DRAWING IS THE SOLE PROPERTY OF BELDEN UNIVERSAL. ANY REPRODUCTION IN PART OR AS A WHOLE WITHOUT THE WRITTEN PERMISSION OF BELDEN UNIVERSAL IS PROHIBITED.	STANDARD TOLERANCES, UNLESS OTHERWISE SPECIFIED DIMENSIONS ARE IN INCHES [mm] ANGULAR MACHINED: ±1.0° FRACTIONAL: ±.015" TWO PLACE DECIMAL: ±.010" THREE PLACE DECIMAL: ±.005" FOUR PLACE DECIMAL: ±.0005" CONCENTRICITY: .0005" T.I.R. ALL HOLES TO BE LOCATED ON CENTERLINE (C) WITHIN .005" T.I.R. INTERPRET GEOMETRIC TOLERANCES I.A.W. ASME Y14.5	MATERIAL: STAINLESS STEEL HEAT TREAT: SELECTIVE FINISH: NONE	INITIALS: AJH DATE: 24 JUL 18 CHECKED: JP DATE: 07/25/2018 ENG APPR: MFG APPR: QC APPR: COMMENTS:	Belden Incorporated www.beldenuniversal.com TITLE: ASSEMBLY, UNIVERSAL JOINT SIZE: A DWG. NO.: UJ-SS3000x1500 SCALE: 1:1.2 WGT (Lbs): 13.214 SHEET 1 OF 2
	MATERIAL: STAINLESS STEEL	INITIALS: AJH DATE: 24 JUL 18	TITLE: ASSEMBLY, UNIVERSAL JOINT	DWG. NO.: UJ-SS3000x1500
	HEAT TREAT: SELECTIVE	CHECKED: JP DATE: 07/25/2018	COMMENTS:	REV:
	FINISH: NONE	ENG APPR: MFG APPR: QC APPR:	SCALE: 1:1.2 WGT (Lbs): 13.214 SHEET 1 OF 2	SHEET 1 OF 2