

# APPROVED

REVISIONS				
ZONE	REV.	DESCRIPTION	DATE	APPROVED
	A	INITIAL RELEASE	8/23/2019	JP

## FOR REFERENCE ONLY

SOC. SET SCREW, M8x1.25 x 8mm, CUP POINT, 18-8 STAINLESS ST'L 2X

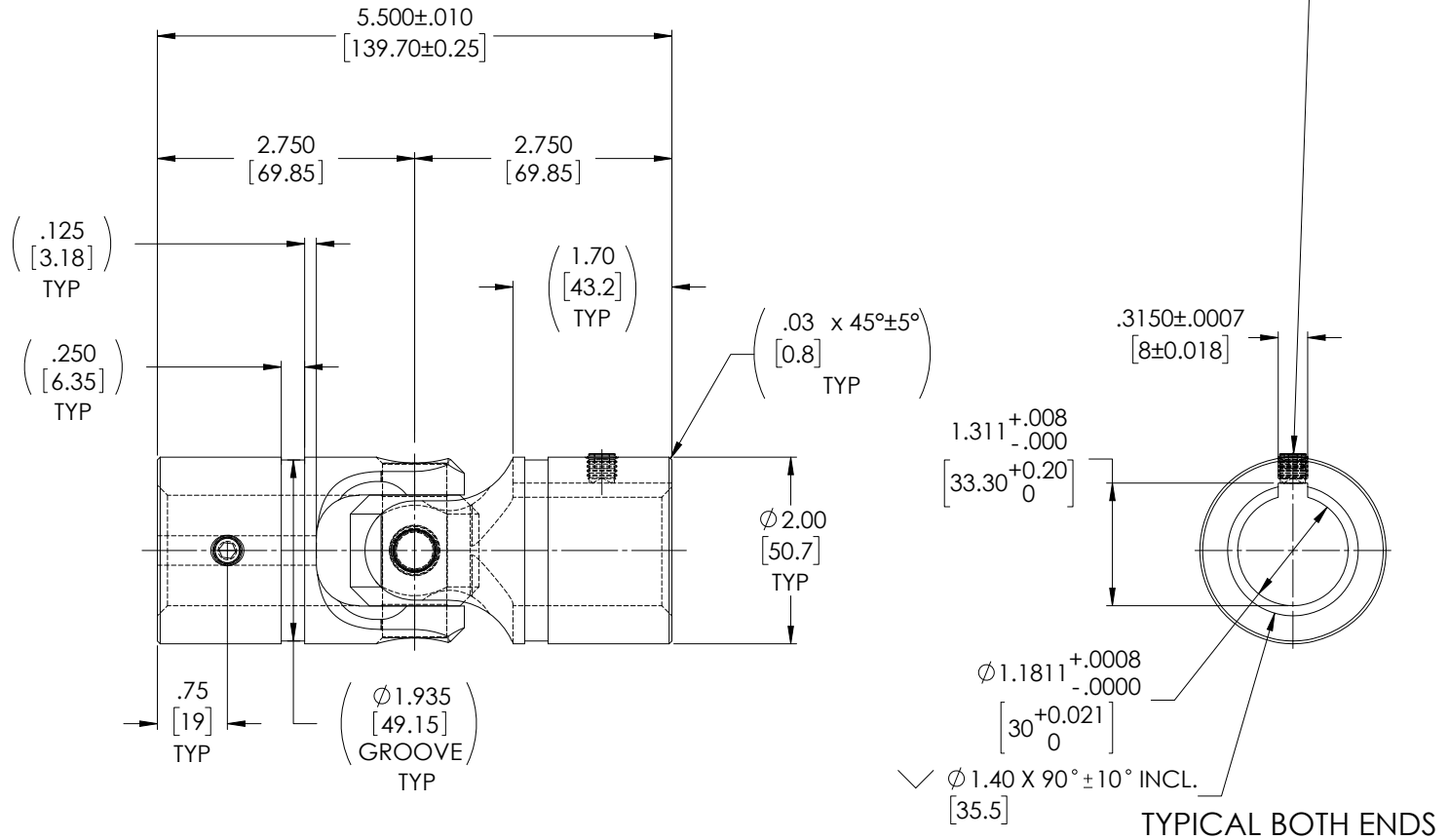
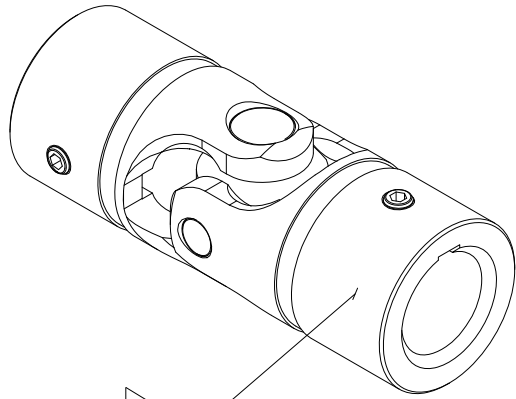

NOTE(s), UNLESS OTHERWISE SPECIFIED.

1 MARK ASSEMBLY w/ "BELDEN" LOGO, PART NUMBER, REVISION LEVEL (IF ANY), DATE OF MANUFACTURE & BELDEN JOB No.

2) LUBRICATE U-JOINT w/ LUBRIPLATE # 1200-2, NLGI GRADE 2, AW/EP, LITHIUM GREASE OR EQUIVALENT.

3) REFERENCE, MATERIAL: YOKES... TYPE 303 STAINLESS STEEL, BLOCK & PINS... TYPE 416 STAINLESS STEEL, RETAINING RING... TYPE 302 STAINLESS STEEL, SET SCREWS... TYPE 18-8 STAINLESS STEEL.

4) REF., MAXIMUM OPERATING ANGLE: 45°

DO NOT SCALE DRAWING

UNLESS OTHERWISE SPECIFIED CHAMFER ALL HOLES BREAK ALL SHARP CORNERS DE-BURR ALL FEATURES  TURNED SURFACES: $\sqrt{63}$ MILLED SURFACES: $\sqrt{125}$  <b>PROPRIETARY AND CONFIDENTIAL</b> THE INFORMATION CONTAINED IN THIS DRAWING IS THE SOLE PROPERTY OF BELDEN UNIVERSAL. ANY REPRODUCTION IN PART OR AS A WHOLE WITHOUT THE WRITTEN PERMISSION OF BELDEN UNIVERSAL IS PROHIBITED.	STANDARD TOLERANCES, UNLESS OTHERWISE SPECIFIED  DIMENSIONS ARE IN INCHES (mm) ANGULAR MACHINED: $\pm 1.0^\circ$ FRACTIONAL: $\pm .015$ TWO PLACE DECIMAL: $\pm .010$ THREE PLACE DECIMAL: $\pm .005$ FOUR PLACE DECIMAL: $\pm .0005$ CONCENTRICITY: $.0005$ T.I.R.	MATERIAL: STAINLESS STEEL  HEAT TREAT: SEE DETAIL DRAWINGS  FINISH: NONE	INITIALS: JP DATE: 23AUG19  CHECKED: RNK DATE: 09/16/2019  ENG APPR: RNK DATE: 09/16/2019  MFG APPR: DATE:  QC APPR:	Belden Incorporated www.beldenuniversal.com  TITLE: ASSEMBLY, UNIVERSAL JOINT  SIZE: A DWG. NO.: UJ-SS2000x30K WT (Lbs): 3.043 REV: A SHEET 1 OF 2
	COMMENTS:			SCALE: 1:1
	ALL HOLES TO BE LOCATED ON CENTERLINE (C) WITHIN .005" T.I.R. INTERPRET GEOMETRIC TOLERANCES I.A.W. ASME Y14.5			SCALE: 1:1   WT (Lbs): 3.043   SHEET 1 OF 2
	UNLESS OTHERWISE SPECIFIED CHAMFER ALL HOLES BREAK ALL SHARP CORNERS DE-BURR ALL FEATURES  TURNED SURFACES: $\sqrt{63}$ MILLED SURFACES: $\sqrt{125}$  <b>PROPRIETARY AND CONFIDENTIAL</b> THE INFORMATION CONTAINED IN THIS DRAWING IS THE SOLE PROPERTY OF BELDEN UNIVERSAL. ANY REPRODUCTION IN PART OR AS A WHOLE WITHOUT THE WRITTEN PERMISSION OF BELDEN UNIVERSAL IS PROHIBITED.			SCALE: 1:1   WT (Lbs): 3.043   SHEET 1 OF 2