

APPROVED

FOR REFERENCE ONLY

SOCKET SET SCREW, M6x1.0 x 6mm, CUP POINT, 18-8 STAINLESS ST'L, 2X

REVISIONS				
ZONE	REV.	DESCRIPTION	DATE	APPROVED
	A	INITIAL RELEASE	8/23/2019	JP

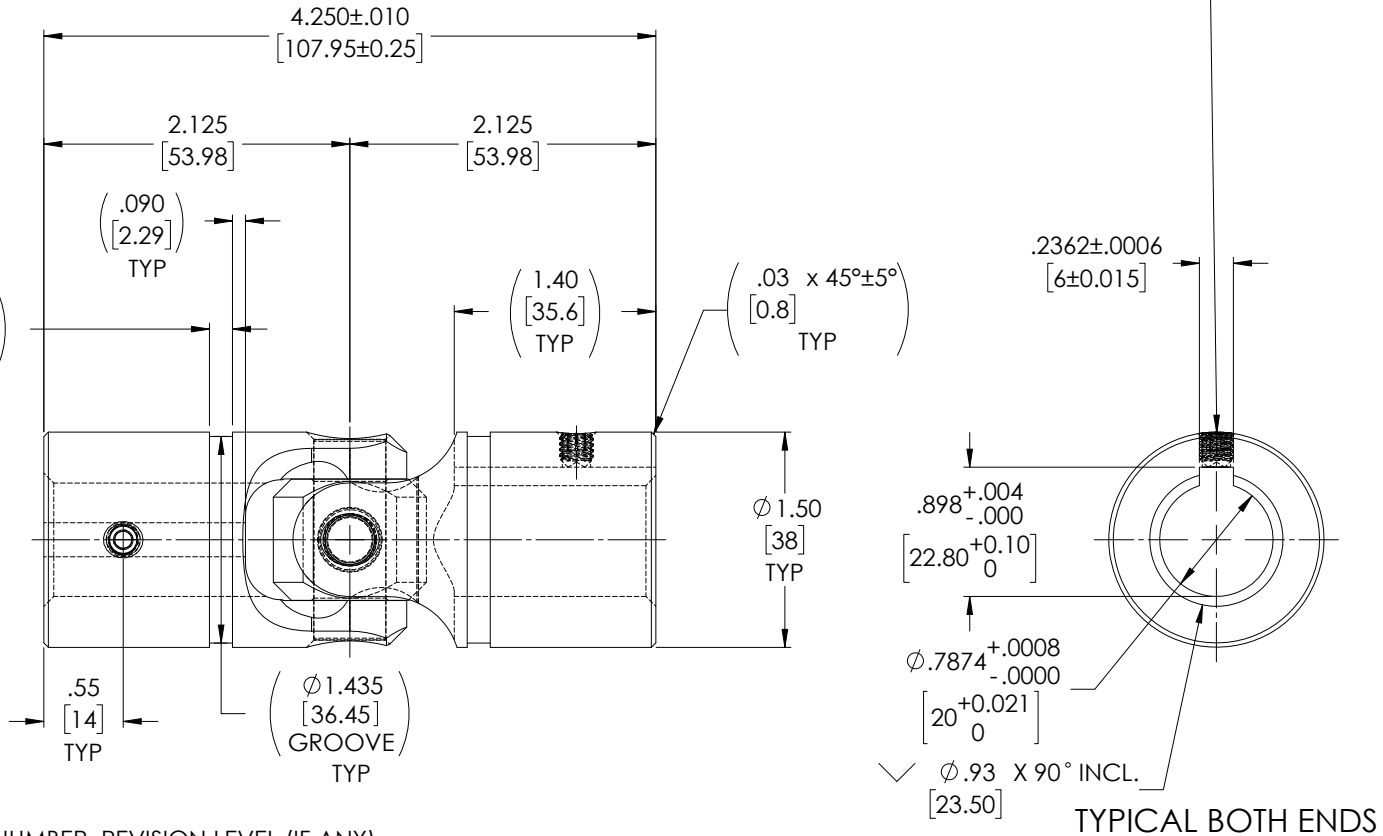
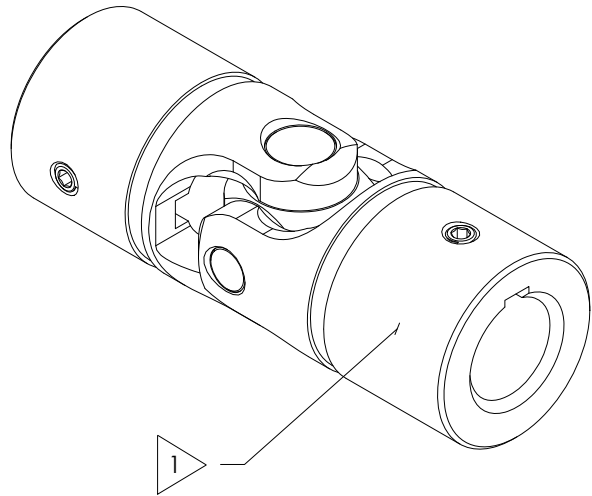

NOTE(s), UNLESS OTHERWISE SPECIFIED.

1 MARK ASSEMBLY w/ "BELDEN" LOGO, PART NUMBER, REVISION LEVEL (IF ANY), DATE OF MANUFACTURE & BELDEN JOB No.

(2) LUBRICATE U-JOINT w/ LUBRIPLATE # 1200-2, NLGI GRADE 2, AW/EP, LITHIUM GREASE OR EQUIVALENT.

(3) REFERENCE, MATERIAL: YOKES... TYPE 303 STAINLESS STEEL, BLOCK & PINS... TYPE 416 STAINLESS STEEL, RETAINING RING... TYPE 302 STAINLESS STEEL, SET SCREWS... TYPE 18-8 STAINLESS STEEL.

(4) REF., MAXIMUM OPERATING ANGLE: 45°

DO NOT SCALE DRAWING

UNLESS OTHERWISE SPECIFIED CHAMFER ALL HOLES BREAK ALL SHARP CORNERS DE-BURR ALL FEATURES TURNED SURFACES: $\sqrt{63}$ MILLED SURFACES: $\sqrt{125}$ PROPRIETARY AND CONFIDENTIAL THE INFORMATION CONTAINED IN THIS DRAWING IS THE SOLE PROPERTY OF BELDEN UNIVERSAL. ANY REPRODUCTION IN PART OR AS A WHOLE WITHOUT THE WRITTEN PERMISSION OF BELDEN UNIVERSAL IS PROHIBITED.	STANDARD TOLERANCES, UNLESS OTHERWISE SPECIFIED DIMENSIONS ARE IN INCHES (mm)	MATERIAL: STAINLESS STEEL HEAT TREAT: SEE DETAIL DRAWINGS FINISH: NONE	INITIALS: JP DATE: 23AUG19 DRAWN: RNK CHECKED: RNK ENG APPR: RNK MFG APPR: QC APPR:	Belden Incorporated www.beldenuniversal.com TITLE: ASSEMBLY, UNIVERSAL JOINT	
	ANGULAR MACHINED: $\pm 1.0^\circ$ FRACTIONAL: ± 0.015 TWO PLACE DECIMAL: ± 0.010 THREE PLACE DECIMAL: ± 0.005 FOUR PLACE DECIMAL: ± 0.0005 CONCENTRICITY: 0.0025 T.I.R.	ALL HOLES TO BE LOCATED ON CENTERLINE (C) WITHIN .005" T.I.R. INTERPRET GEOMETRIC TOLERANCES I.A.W. ASME Y14.5	COMMENTS:	SIZE: A DWG. NO.: UJ-SS1500x20K SCALE: 3:2 WT (Lbs): 1.453 SHEET 1 OF 2	REV: A
	FORM SW-A 5-18 8				
	Page 1 of 2				