

REVISIONS				
ZONE	REV.	DESCRIPTION	DATE	APPROVED

# INFORMATION IN THIS DRAWING PROVIDED FOR REFERENCE ONLY

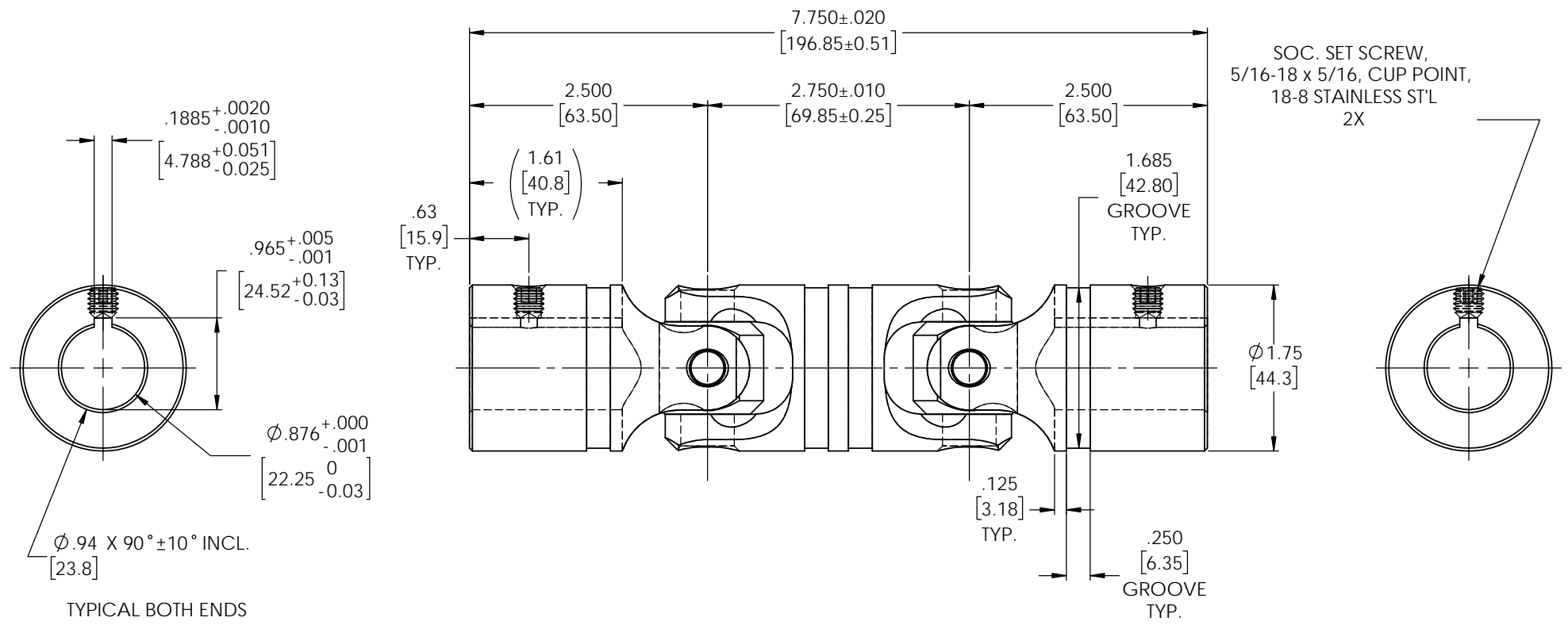

- NOTE(S), UNLESS OTHERWISE SPECIFIED.
- (1) UNIVERSAL JOINT IS MARKED w/ "BELDEN" LOGO, PART NUMBER / DRAWING NUMBER, REVISION LEVEL (IF ANY), DATE OF MANUFACTURE (MO/YR), AND BELDEN JOB NUMBER.
  - (2) UNIVERSAL JOINT IS LUBRICATED w/ LUBRIPLATE 1200-2, NLGI GRADE 2, AW/EP, LITHIUM GREASE OR EQUIVALENT.
  - (3) UNIVERSAL JOINT IS CAPABLE OF OPERATING AT ANY ANGLE UP TO AND INCLUDING 45°, 90° FOR THE DOUBLE UNIVERSAL JOINT.
  - (4) UNIVERSAL JOINT HAS STANDARD GROOVES TO ACCEPT INSTALLATION OF PROTECTIVE COVERS (BOOTS). BOOTS AVAILABLE SEPARATELY. REFER TO BELDEN CATALOG, WEBSITE, OR CONTACT BELDEN SALES.
  - (5) REFER TO BELDEN CATALOG, WEBSITE, OR CONTACT BELDEN SALES FOR TORQUE CAPACITY.
  - (6) THIS DRAWING REPRESENTS A STANDARD BELDEN ITEM. CUSTOM UNIVERSAL JOINTS ARE AVAILABLE UPON REQUEST. PLEASE CONTACT BELDEN SALES.

## BELDEN P/N DUJ-SS1750x875K

DO NOT SCALE DRAWING

UNLESS OTHERWISE SPECIFIED CHAMFER ALL HOLES BREAK ALL SHARP CORNERS DE-BURR ALL FEATURES TURNED SURFACES: $\sqrt{63}$ MILLED SURFACES: $\sqrt{125}$	STANDARD TOLERANCES, UNLESS OTHERWISE SPECIFIED DIMENSIONS ARE IN INCHES (mm) ANGULAR MACHINED: $\pm 1.0^\circ$ FRACTIONAL: $\pm 0.015$ TWO PLACE DECIMAL: $\pm 0.010$ THREE PLACE DECIMAL: $\pm 0.005$ FOUR PLACE DECIMAL: $\pm 0.0005$ CONCENTRICITY: $0.0025$ T.I.R.	MATERIAL: STAINLESS STEEL HEAT TREAT: SEE DETAIL DRAWINGS FINISH: NONE	INITIALS: AJH DATE: 17 JUL 18 CHECKED: JP DATE: 07/18/2018 ENG APPR: MFG APPR: QC APPR:	Belden Universal <a href="http://www.beldenuniversal.com">www.beldenuniversal.com</a> TITLE: ASSEMBLY, DOUBLE UNIVERSAL JOINT, STAINLESS STEEL	
	PROPRIETARY AND CONFIDENTIAL THE INFORMATION CONTAINED IN THIS DRAWING IS THE SOLE PROPERTY OF BELDEN UNIVERSAL. ANY REPRODUCTION IN PART OR AS A WHOLE WITHOUT THE WRITTEN PERMISSION OF BELDEN UNIVERSAL IS PROHIBITED.	ALL HOLES TO BE LOCATED ON CENTERLINE (C) WITHIN .005" T.I.R. INTERPRET GEOMETRIC TOLERANCES I.A.W. ASME Y14.5	COMMENTS:	SIZE: A DWG. NO.: DUJ-SS1750x875K SCALE: 5:4 WT (Lbs): 3.790 SHEET 1 OF 2	REV: